

Joist Trak™ Heat-Transfer Panel Installation Handbook

Joist Trak™ Heat-Transfer Panel Installation Handbook

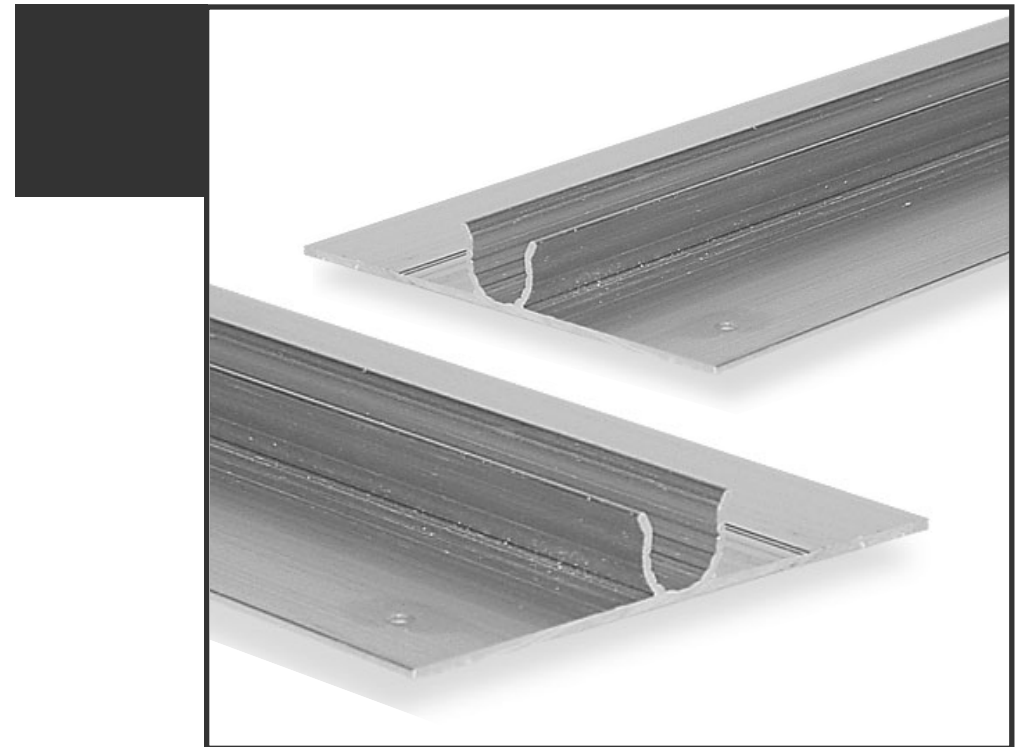

Joist Trak™ Heat-Transfer Panel Overview

Introduction

Joist Trak™ heat-transfer panels provide fast and effective installation of radiant heat in virtually every application (floors, walls and ceilings). The rigid channel construction makes it easier for flexible hePEX™ plus tubing to be snapped into place tightly and securely. Joist Trak is also an excellent alternative to poured floor underlayments.

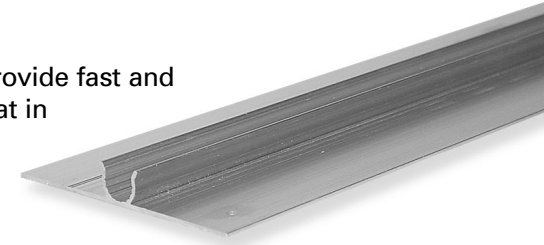

- Outstanding for both new construction and retrofit
- Excellent thermal conductivity makes it the ideal material for today's radiant heating systems
- Increased heat output and more uniform floor temperatures, at lower water temperatures, compared to staple-up installations
- Easily installed from below the subfloor with no alteration to existing or planned wood-frame floor construction
- Adaptable for above floor, wall and ceiling applications
- No need for additional straps or fasteners to secure hePEX plus tubing
- Open-channel design leaves tubing runs fully visible and accessible during installation
- Convenient 4-foot lengths simplify ordering, handling and installation (if necessary, Joist Trak can be easily cut to length on the job)
- Joist Trak system's low mass allows for quicker response time to changes in room temperature compared to high-mass systems

Joist Trak Heat-Transfer Panel Specifications

Product Name	Part Number	
Wirsbo Joist Trak 3/8"	A5080375	
Wirsbo Joist Trak 1/2"	A5080500	
Technical Information	3/8"	1/2"
Overall Height	0.550"	0.675"
Internal Channel Diameter	0.515"	0.640"
Wall Thickness	0.050"	0.050"
Width	4"	4"
Length	48"	48"

Typical Joist Trak Construction Method

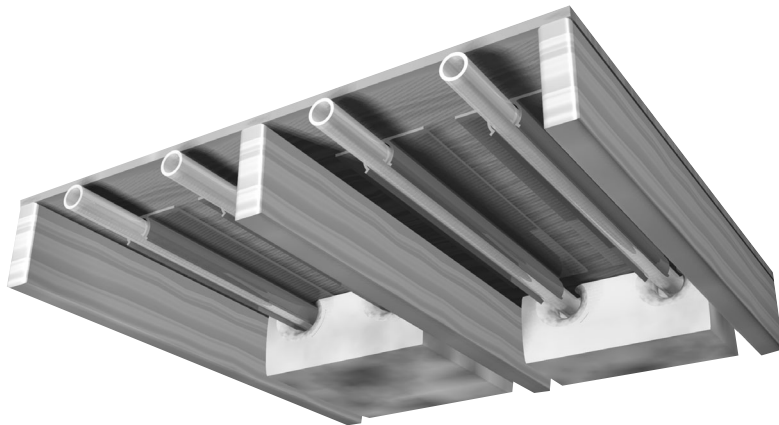

Filler Boards

When installing Joist Trak panels to the face of a wall or ceiling, it is necessary to provide 5/8-inch thick filler boards between the channels of the Trak panels (5/8-inch sheetrock is commonly used). For 8-inch on-center wall spacing, use 7-inch wide filler boards. For 12-inch on-center ceiling spacing, use 11-inch wide filler boards.

The filler boards or sheetrock provide an even surface for finish material application. Install 3/8- or 1/2-inch sheetrock directly over the filler boards.

Manifold Connections and System Start-up

See Section 9 of the Wirsbo Heating Installation Handbook for specific manifold connections and system start-up instructions.

Tubing Runs for Joist Trak Installation

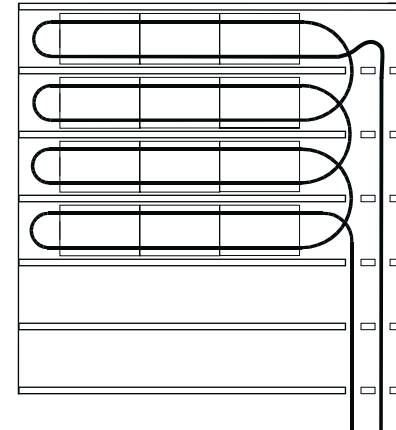

Below Subfloor Installation

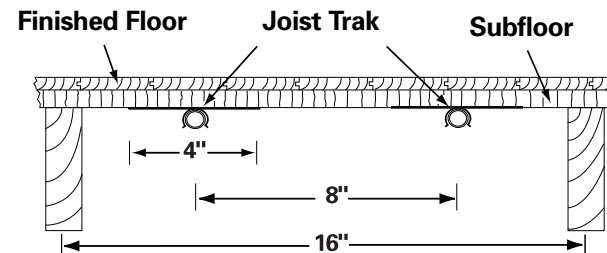

Joist Trak Heat-Transfer Panel Installation

Joist Trak Installation

Install the Joist Trak panels with either screws or nails into the pre-punched mounting holes. If available, a power nailer or screw gun helps facilitate the installation process. Install the panels with a minimum ¼-inch gap between them to allow for expansion and contraction. This gap can also be as wide as 5 inches to help maximize the Joist Trak coverage area and minimize the amount of panels that have to be cut to fit into the end of joist bays. The ends of all joist bays require a minimum of 12 inches and a maximum of 18 inches to loop the tubing from panel-to-panel and bay-to-bay.

Note: Joist Trak panels are easily cut on a standard miter saw (with a carbide blade) or with a hand hacksaw. Remove any burrs left on the Joist Trak panels before installing them.

Installing the Tubing

Once the Joist Trak panels are installed, snap the tubing into the channel of the panels. Use a rubber mallet to tap the tubing securely into place. When working overhead, use a suitable length of construction lumber (2" x 4") to push the tubing into place.

When drilling holes in joists for the tubing to pass from bay to bay, allow sufficient clearance for sleeving of the tubing. Never exceed the tubing's minimum bending radius, and make sure the tubing does not rub against the joist hole. See Chapter 5 in the Wirsbo CDAM for more information about construction methods.

Insulation

Install fiberglass batt insulation below all Joist Trak installations. Failure to provide suitable insulation decreases system efficiency and may not allow for sufficient heat output. Install insulation tightly against the Joist Trak panels to minimize air gaps between the subfloor and the insulation.

Joist Trak Heat-Transfer Panel Design

Design Notes

The Joist Trak heating system design incorporates many of the same required calculations and parameters discussed in Chapters 7 and 8 of the Wirsbo Complete Design Assistance Manual (CDAM). However, Joist Trak design utilizes a separate Water Temperature Chart (see chart on **page 4**) and uses a simple material calculation formula for the panels.

Step 1

Determine the Heating BTU/h Requirements

Perform a complete room-by-room, heat-loss analysis of the areas to be heated using the Wirsbo Advance Design Suite™ (ADS) software package. (For information about radiant floor and ceiling system design, see Chapters 7 and 8 in the Wirsbo CDAM or contact your local wholesaler.)

Step 2

Determine the Required Heat Output

Once the heating requirement (heat loss) is known, use the following formula to determine the BTU/ft² output required.

$$\text{Required Heat Output (BTU/ft}^2\text{)} = \frac{\text{Heat Loss}}{\text{Net Area (sq. ft.)}}$$

Step 3

Select the Tubing Size and Joist Trak Spacing

The Joist Trak system is generally based on an 8-inch on-center design to accommodate the typical 16-inch on-center floor joist construction found in most modern wood-frame structures. It is possible to find 24-inch on-center spacing in older homes. As this spacing is still a multiple of eight, 8-inch on-center Joist Trak spacing remains applicable.

Discuss construction practices and joist spacing that differ from the above, as well as structures with low-heating requirements with an experienced designer to determine acceptable Joist Trak spacing and system alternatives.

Joist Trak is available for either 3/8" or 1/2" tubing. Larger tubing is not used due to the common space constraints when working within joist bays. Wirsbo recommends 3/8" Joist Trak panels for installations below the subfloor and other space-constrained applications. Use 3/8" Joist Trak panels for wall and ceiling applications as well.

Step 4

Determine the System Supply-Water Temperature

Use the Joist Trak Water Temperature Chart (below) to determine the system supply-water temperature.

1. Find the required Joist Trak output on the left side of the chart and extend a line to intersect with the floor covering R-value line.
2. From this intersection, extend another line straight down. Find the supply water temperature at the bottom of the chart.
3. If the supply water temperature is above 160°F, or if the surface temperature is above 87.5°F:
 - a. Check the heat-loss calculations for accuracy.
 - b. Choose a floor covering with a lower R-value if possible.
 - c. Reduce the heat loss of the area (e.g., increased insulation, new windows).
 - d. Include supplemental heating for the area (e.g., Joist Trak wall or ceiling heating, baseboard, air handler, etc.).

**Water Temperature Chart
Based on 8-inch On-center Spacing**

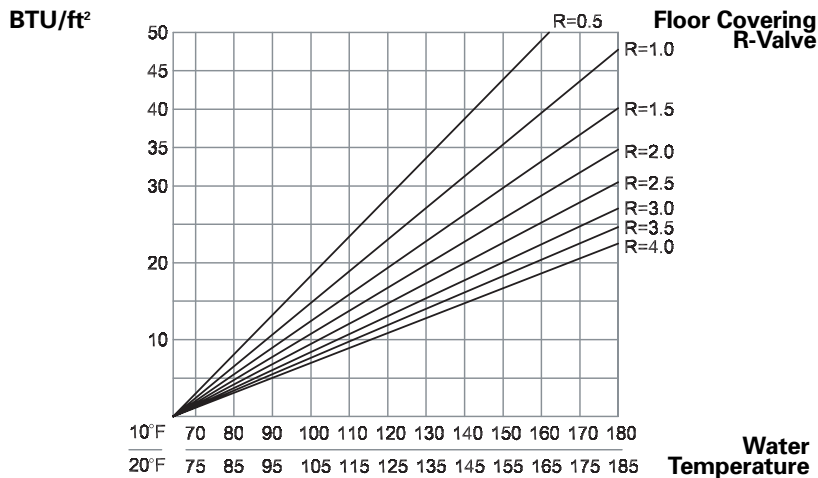

Step 5 Calculate the Tubing and Joist Trak Panels Needed

Tubing

Multiply the net area by 1.5 to determine the tubing required for 8-inch on-center spacing. Be sure to include the supply and return runs to the manifold location.

Joist Trak

Multiply the total length of tubing by 0.85. This takes into account the turns at the end of each run that are not used by Joist Trak. (Do not include the supply and return runs to the boiler and manifold for this calculation.) Divide this number by four (for 4-foot Joist Trak lengths) to get the estimated number of Joist Trak panels required for the area.

Number of Loops

The maximum circuit length for a Joist Trak loop is 200 feet for 3/8" tubing and 300 feet for 1/2" tubing. The maximum area that can be covered per loop using 8-inch on-center Joist Trak spacing, including a 10-foot supply and return leader, is 186 sq. ft. using 3/8" tubing and 247 sq. ft. using 1/2" tubing. Taking into account the supply and return runs to the manifold location, determine the number of loops. If the boiler location is a great distance from the area to be heated, establish a remote manifold location.

Step 6 Calculate the Flow Rate and Pressure Drop

See Appendices G and H in the Wirsbo CDAM to calculate the flow rate and pressure drop.